

TECHNICAL DATA SHEET

FAST FOOD EQUIPMENT BAR BLENDERS



- Manual and digital model option
- Mix and pulse option
- Max. 25.000 RPM working speed
- Lid sensor
- 3 or 2 Lt jug capacity
- Speed control
- Ice crushing feature
- ABS Body
- Polycarbonate container suitable for food contact



Figure 1 Control Panel

- A: ON - OFF switch
- B: PULSE switch
- C: Speed control button





TECHNICAL DATA SHEET

BLE3-R

Capacity: 3LT
Dimension (mm): 210x240x490
Weight (kg): 4,7
Pack. Dimension (mm): 250x440x280
Gross Weight (kg): 8
Electric Input (V): 230
Cable (mm²): 3x1
Power (KW): 2,2
Fuse (A): 1x16

BLE2-R

Capacity: 2LT
Dimension (mm): 210x240x430
Weight (kg): 4,5
Pack. Dimension (mm): 250x440x280
Gross Weight (kg): 8
Electric Input (V): 230
Cable (mm²): 3x1
Power (KW): 2,2
Fuse (A): 1x16

BLE3-B

Capacity: 3LT
Dimension (mm): 210x240x490
Weight (kg): 4,7
Pack. Dimension (mm): 250x440x280
Gross Weight (kg): 8
Electric Input (V): 230
Cable (mm²): 3x1
Power (KW): 2,2
Fuse (A): 1x16

BLE2-B

Capacity: 2LT
Dimension (mm): 210x240x430
Weight (kg): 4,5
Pack. Dimension (mm): 250x440x280
Gross Weight (kg): 8
Electric Input (V): 230
Cable (mm²): 3x1
Power (KW): 2,2
Fuse (A): 1x16

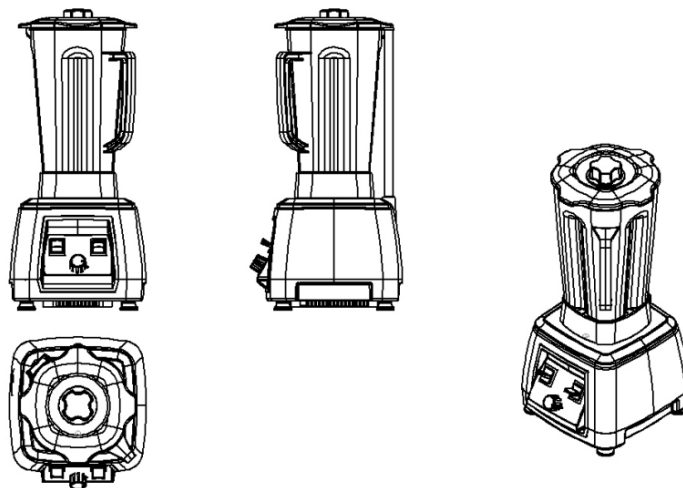

FAST FOOD EQUIPMENT BAR BLENDERS

